

Carbon input by roots into the soil: Quantification of rhizodeposition from root to ecosystem scale

Johanna Pausch^{1,2}  | Yakov Kuzyakov^{2,3,4} 

¹Department of Agroecology, University of Bayreuth, Bayreuth, Germany

²Department of Soil Science of Temperate Ecosystems, Georg-August-University, Göttingen, Germany

³Department of Agricultural Soil Science, Georg-August-University, Göttingen, Germany

⁴Institute of Environmental Sciences, Kazan Federal University, Kazan, Russia

Correspondence

Johanna Pausch, Department of Agroecology, University of Bayreuth, Bayreuth, Germany.
Email: johanna.pausch@uni-bayreuth.de

Funding information

Deutsche Forschungsgemeinschaft

Abstract

Despite its fundamental role for carbon (C) and nutrient cycling, rhizodeposition remains 'the hidden half of the hidden half': it is highly dynamic and rhizodeposits are rapidly incorporated into microorganisms, soil organic matter, and decomposed to CO₂. Therefore, rhizodeposition is rarely quantified and remains the most uncertain part of the soil C cycle and of C fluxes in terrestrial ecosystems. This review synthesizes and generalizes the literature on C inputs by rhizodeposition under crops and grasslands (281 data sets). The allocation dynamics of assimilated C (after ¹³C-CO₂ or ¹⁴C-CO₂ labeling of plants) were quantified within shoots, shoot respiration, roots, net rhizodeposition (i.e., C remaining in soil for longer periods), root-derived CO₂, and microorganisms. Partitioning of C pools and fluxes were used to extrapolate belowground C inputs via rhizodeposition to ecosystem level. Allocation from shoots to roots reaches a maximum within the first day after C assimilation. Annual crops retained more C (45% of assimilated ¹³C or ¹⁴C) in shoots than grasses (34%), mainly perennials, and allocated 1.5 times less C belowground. For crops, belowground C allocation was maximal during the first 1–2 months of growth and decreased very fast thereafter. For grasses, it peaked after 2–4 months and remained very high within the second year causing much longer allocation periods. Despite higher belowground C allocation by grasses (33%) than crops (21%), its distribution between various belowground pools remains very similar. Hence, the total C allocated belowground depends on the plant species, but its further fate is species independent. This review demonstrates that C partitioning can be used in various approaches, e.g., root sampling, CO₂ flux measurements, to assess rhizodeposits' pools and fluxes at pot, plot, field and ecosystem scale and so, to close the most uncertain gap of the terrestrial C cycle.

KEYWORDS

belowground carbon allocation, carbon cycle, crops, grasses, isotopic approaches, rhizosphere microorganisms, root exudation, soil CO₂ efflux, trees

1 | INTRODUCTION

1.1 | Importance of rhizodeposition for belowground processes

Plants transform atmospheric CO₂ into soil organic carbon (C), thereby connecting the abiotic and biotic parts of the C cycle.

Globally some 60 Gt C year⁻¹, or half of all C assimilated by land plants, is transferred from the vegetation into the soil, either as root and shoot litter after plant death or as C released by living roots (Lal, 2008; Paterson, Midwood, & Millard, 2009; Schlesinger, 1997). The organic compounds released by living roots into the soil are collectively referred to as rhizodeposits, and the corresponding process as rhizodeposition (Jones, Nguyen, & Finlay, 2009; Kuzyakov &

Domanski, 2000). Rhizodeposition regulates a wide range of ecological soil functions and properties such as specific and unspecific nutrient mobilization and nutrient availability (Hütsch, Augustin, & Merbach, 2002), water fluxes (Moradi et al., 2012), formation of aggregates (Six, Bossuyt, Degryze, & Deneff, 2004), C turnover and C sequestration (Kögel-Knabner, 2002), structuring of microbial communities (Paterson, Gebbing, Abel, Sim, & Telfer, 2007), and maintaining their activities at high level (Kuzyakov & Blagodatskaya, 2015). Most of the biogeochemical and physical differences between the rhizosphere and the surrounding soil are caused by the release of highly bioavailable, low-molecular weight organic substrates originating from root exudates of intact cells, lysates of sloughed-off cells and dead tissues, and from mucilage (Dennis, Miller, & Hirsch, 2010; Neumann & Römhild, 2007). These substrates play a predominant role in microbially mediated processes in soil, as they supply heterotrophic microbial communities with available C and energy promoting the cycling of all elements.

Because of the importance of rhizodeposition, earlier reviews have summarized the amount and controlling factors of rhizodeposition (Grayston, Vaughan, & Jones, 1996; Jones, Hodge, & Kuzyakov, 2004), the mechanisms of rhizodeposition and quantity of rhizodeposits (Nguyen, 2003), and the interactions between rhizodeposition, microbially mediated processes and C cycling (e.g., Dennis et al., 2010; Jones et al., 2009; Paterson, 2003). The last review to examine the amount of C released by roots of cereals and grasses was published 17 years ago, and was constrained by the number of articles at that time, and restricted itself to experiments conducted solely under controlled laboratory conditions (Kuzyakov & Domanski, 2000). Since 2000, many new data sets have been published. Studies have concentrated on C partitioning in various plant–soil systems providing quantitative estimates of the fractions of assimilated C allocated to each C pool in plants and soils (Epron et al., 2012).

1.2 | Challenges of rhizodeposition quantification

Gross rhizodeposition is the total input of organic C via living roots into the soil, whereas net rhizodeposition is defined as the part of the C that remained in the soil after microbial utilization and partial decomposition to CO₂. Rhizodeposition, especially gross rhizodeposition, remains very difficult to assess. The main obstacles are (Kuzyakov & Domanski, 2000): (i) the restriction to a narrow zone around the root, (ii) fast microbial utilization and, in part, decomposition, (iii) the much lower content compared to other organic compounds in soil, and (iv) chemical similarity to organic substances released by microorganisms that decompose soil organic matter (SOM) and litter.

Stable (¹³C) and radioactive (¹⁴C) isotope labeling techniques and ¹³C natural abundance approaches are the best available tools to overcome these difficulties and separate root-derived C from SOM-derived C (Kuzyakov & Domanski, 2000; Kuzyakov & Schneckengerber, 2004; Meharg, 1994; Nguyen, 2003; Werth & Kuzyakov, 2008; Whipps, 1990). Pulse labeling of plants by short-term

exposure to ¹³C- or ¹⁴C-labeled CO₂ allows, in contrast to continuous labeling and ¹³C natural abundance approach, to analyze the dynamics of C allocation within the plant–soil system.

Belowground C input by plants and C partitioning (relative allocation of assimilated C) reflect allocation strategies of the plants (Farrar & Jones, 2000; Weiner, 2004). Carbon partitioning vary with plant development stage (reflecting changing priorities), but also depends on species-specific strategies (Weiner, 2004), such as preferred allocation to belowground storage compounds (Kuzyakov & Domanski, 2000), protection against grazing (Schleuss et al., 2015) or responses to environmental conditions, e.g., drought (Sanauallah, Chabbi, Rumpel, & Kuzyakov, 2012), N deposition, atmospheric CO₂ concentration, heat waves, and other global change effects (Grayston et al., 1996).

The scale of rhizodeposition is still very uncertain and it remains the most “hidden” part of the C cycle. This is especially true under field conditions, due to the limited number of ¹³C and ¹⁴C pulse studies. However, even under controlled conditions individual studies differ greatly in experimental set-up, sampling strategy and timing, as well as growth conditions, making direct comparison difficult. A careful synthesis and consolidation of the literature is therefore required.

1.3 | Objectives

The objectives of this review were to (i) summarize and standardize the results of studies estimating rhizodeposition, (ii) analyze the dynamics of plant-assimilated C in the main above- and belowground pools and fluxes, (iii) generalize C partitioning in plant–soil systems that can be used in a broad range of ecosystem studies to estimate rhizodeposition under field conditions, (iv) assess the effects of various plant and environmental factors on total belowground C input, and (v) provide examples for upscaling rhizodeposition from individual plants to plot and ecosystem scales. The review focuses on two functional vegetation groups: grassland species and main agricultural crops and includes the data available for trees.

2 | MATERIALS AND METHODS

2.1 | Data collection

Data were collected only from experiments that applied pulse labeling of plants in a ¹³CO₂ or ¹⁴CO₂ atmosphere. Partitioning of assimilated C was presented in individual studies as (i) ¹⁴C activities or ¹³C amounts in various pools, (ii) total input, i.e., percentage of the labeled C added to the plant atmosphere, (iii) total assimilated C, i.e., gross assimilation, or (iv) C recovery at specific time after labeling, usually excluding shoot respiration (Figure 1).

In the first step of data standardization, literature results were divided into two large groups based on the data provided, so that C partitioning could be recalculated either: (i) as percentage of total assimilated C (C assimilated, Figure 1), or (ii) as percentage of recovery (C recovered, Figure 1).

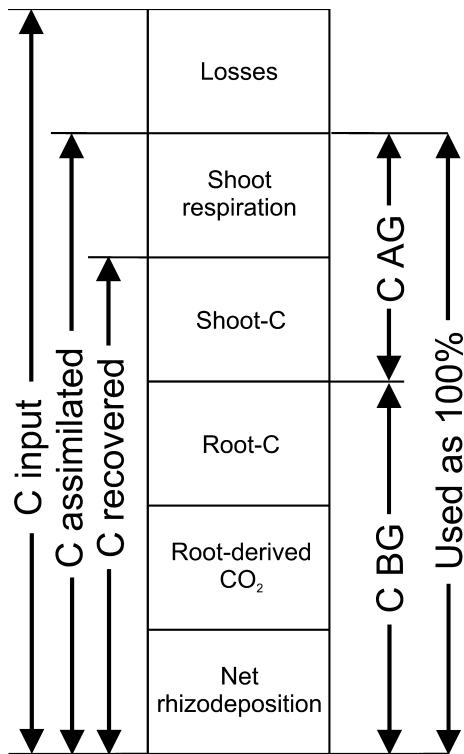

FIGURE 1 Illustration of the C pools in the plant–soil system and comparison of calculation approaches and data presentations used in the literature. For expression of C allocation as percentage, the various approaches consider different C pools: C input = amount of tracer added for labeling; C assimilated = gross amount of tracer assimilated by plants; C recovered = tracer amount recovered in the measured pools at the first sampling or at each sampling (often does not consider shoot respiration). C AG and C BG are the ^{13}C or ^{14}C amounts allocated to aboveground and belowground pools. All literature results were standardized to percent of C assimilated (see *Materials and Methods*)

Percentage of total assimilated C (at each sampling time) is the ratio of tracer incorporation in a certain pool ($n(^{13/14}\text{C})$) and total assimilated C $n(^{13/14}\text{C}_{\text{assimilated}})$, multiplied by 100.

$$\% \text{ of ass.} = \frac{100}{n(^{13/14}\text{C}_{\text{assimilated}})} \cdot n(^{13/14}\text{C}). \quad (1)$$

Percentage of $^{13}\text{C}/^{14}\text{C}$ recovery at a certain time after labeling is calculated by setting the sum of total recovered tracer ($n(^{13/14}\text{C}_{\text{total recovered}})$) in the plant–soil system, i.e., in shoot, root, soil, and soil CO_2 as 100%.

$$\% \text{ of rec.} = \frac{100}{n(^{13/14}\text{C}_{\text{total recovered}})} \cdot n(^{13/14}\text{C}). \quad (2)$$

Most studies with C budgets expressed as percentage of total recovery do not account for the tracer lost as shoot respiration. In these studies, the C distribution in the plant–soil system largely depends on the tracer amount lost via shoot respiration. Without considering shoot respiration, the remaining C pools are overestimated. Shoot respiration is strongly influenced by plant, soil, and environmental conditions, and hence, varies between individual

studies. Without its consideration, the results of several studies could not be reliably compared.

For studies that did not provide shoot respiration data, as was the case in most of the studies, then shoot respiration was estimated as described in the following section. All results were then converted to percentage of assimilated C. This provided a consistent data set, which was also comparable to photoassimilation studies from plant ecophysiology (Figure 1).

2.2 | Standardization of data and assessment of shoot respiration

Data provided in figures in the original papers were extracted using the software DIGITZEIT (Braunschweig, Germany). Data given as percentage of total assimilated C in studies investigating C incorporation into shoot respiration were directly summarized. A plot of shoot respiration against time was prepared (Figure 2), and an exponential function was fitted. Due to the small number of studies on crops and trees that consider shoot respiration, a single curve was fitted for all vegetation types.

To standardize the data from studies that do not consider shoot respiration (i.e., data given as percentage of recovery), percentage of total assimilated C (Shoot Resp. (% of ass.)) was estimated based on the equation calculated from Figure 2 and the period after labeling (t).

$$\text{Shoot Resp. (\% of ass.)} = 36 \cdot (1 - \exp(-0.83 \cdot t)). \quad (3)$$

This approach assumes that shoot respiration was the only path of C loss from the soil–plant system. Leaching of rhizodeposits is absent under controlled conditions and would not have significantly

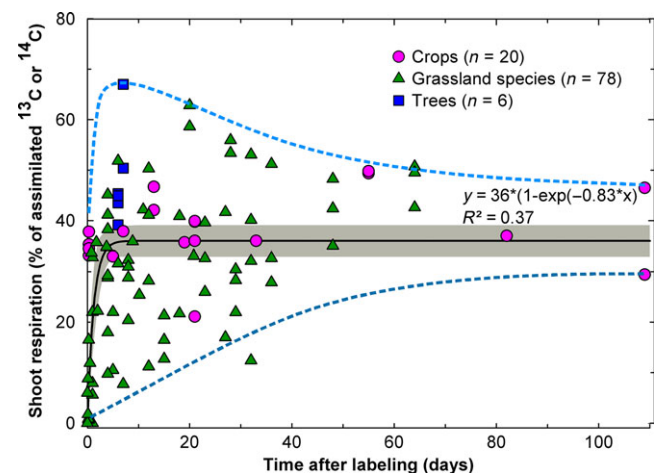

FIGURE 2 Shoot respiration as % of total assimilated C vs. time after labeling. Studies with crops, grassland species, and trees are included. An exponential function ($y = a \cdot (1 - \exp(-b \cdot \text{time}))$) was fitted to all data points. Coefficients of the equation were $a = 36 \pm 1.6$ and $b = 0.8 \pm 0.25$ and were significant ($<.0001$ and $.001$). The gray area represents the 95% confidence band. The dashed lines reflect the distribution of the most data [Colour figure can be viewed at wileyonlinelibrary.com]

biased the results from field investigations, since organic compounds released by roots are almost immediately taken up by microorganisms (Fischer, Ingwersen, & Kuzyakov, 2010).

2.3 | Data analyses and statistics

All data are given as percentage of total assimilated C allocated to a certain pool. After careful evaluation, 44 studies were included. Most of these studies included various treatments (e.g., growth stages, fertilization, drought, elevated CO₂), so, there were ultimately 281 sets of partitioning coefficients. Data were collected for crops, grassland species (here termed 'grasses'), and trees. Four studies conducted on the Tibetan Plateau in alpine meadow ecosystems (Hafner et al., 2012; Wu et al., 2010; Zhao et al., 2015) or wetlands (Gao et al., 2015) were excluded from determination of C allocation to shoots, roots, net rhizodeposition, and root-derived CO₂, because plant life strategies (traits) in these extreme conditions differ greatly from most other ecosystems. Mean C allocation to shoots, roots, net rhizodeposition, and root-derived CO₂ was calculated. Data sets with sampling within the first day after labeling were excluded because C allocation from shoots to belowground pools is incomplete at this time (see Discussion below). Based on C allocation, the shoot-to-root, net rhizodeposition-to-root, and root-derived CO₂-to-root ratios were determined for each data set and mean values over all data sets were calculated.

Based on the first-order exponential decay function fitted to the decline in shoot ¹³C/¹⁴C (% of total assimilated ¹³C/¹⁴C) over time, the half-life and mean residence time of assimilates in shoots of crops and grasses were assessed:

$$N_t = a + N_0 \cdot e^{-\lambda t}, \quad (4)$$

where N_0 and N_t are the percentages of assimilated C in the shoot at the time of maximum label incorporation and at time t , respectively, λ is the rate constant and a is the proportion of assimilated C remaining in the shoots. The half-life ($t_{1/2}$) of C in shoots was calculated based on the rate constant as $t_{1/2} = \ln(2)/\lambda$. The mean residence time (MRT) of C is given as $MRT = 1/\lambda$.

All curve fitting was performed with the software SIGMAPLOT 11 (Systat Software, Inc.). One-way analyses of variance (ANOVA) were used to test for significant differences ($p > .05$) in C allocation to certain pools between crops and grasses. All statistical analyses were performed with STATISTICA for Windows (version 12.0, StatSoft Inc., OK, USA).

3 | RESULTS AND DISCUSSION

3.1 | C allocation to belowground pools

3.1.1 | Percentage of C allocated above- and belowground

The main part of assimilated C remains aboveground and is being used for shoot respiration (Figure 2) and for shoot biomass

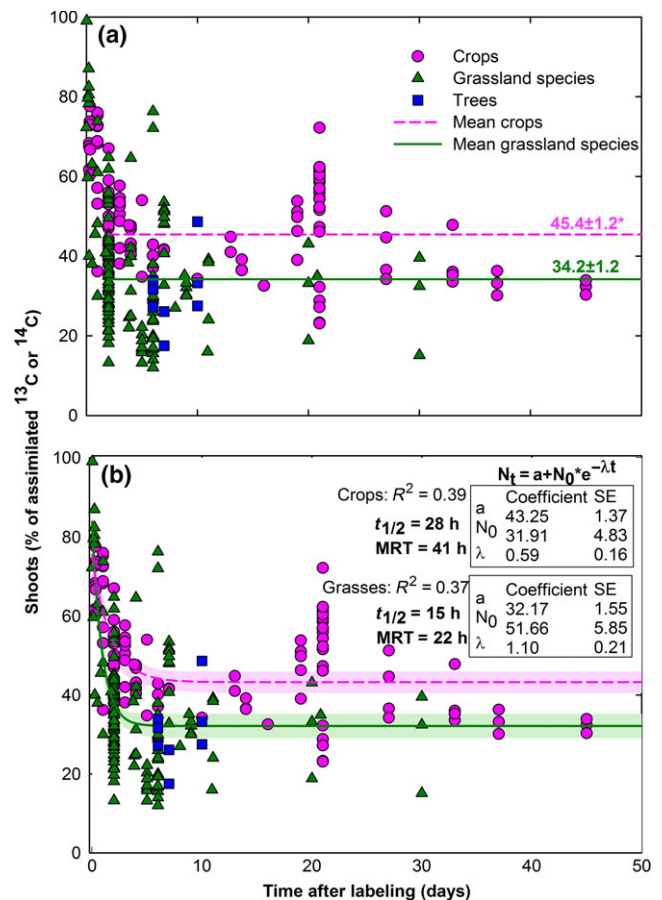

FIGURE 3 (a) Dynamics of recently assimilated C, shown in percent of total assimilated ¹³C/¹⁴C to shoots of crops, grassland species, and trees. The solid lines are the means of all data (>1 day after labeling). The asterisk indicates a significant difference ($p < .05$) between the means of crops and grasses. (b) First-order exponential decay functions (plus a constant) fitted to the decline in shoot ¹³C/¹⁴C (% of total assimilated ¹³C/¹⁴C) over time. All equation parameters are significant at $p < .001$. The filled areas indicate 95% confidence bands. The half-life and mean residence time of assimilates in shoots of crops and grasses are given [Colour figure can be viewed at wileyonlinelibrary.com]

production or C storage (Figure 3). Crops retain more recently assimilated C in shoots (mean 45%; median 43%) than do grasses (mean 34%; median 33%; Figure 3). This reflects (i) the long-term breeding of crops for aboveground biomass production, and (ii) optimization of crop growth by fertilization and management, with a consequent reduction in belowground C allocation. Annual crops translocate less C (21%) belowground than grasses (33%), which are mainly perennials (Figure 4; sum of mean ¹⁴C allocation to all belowground pools). This finding is consistent with the conclusion that annuals release less of their fixed C belowground (Grayston et al., 1996) and with the earlier review showing that pasture plants translocate more C (30%–50%) belowground than cereals (20%–30%) (Kuzyakov & Domanski, 2000). This is because perennial grasses rely on C reserves in roots for regrowth in spring and after grazing or mowing (Paterson, Thornton, Midwood, & Sim, 2005; Schmitt, Pausch, & Kuzyakov, 2013), whereas cereals are bred for high C allocation of

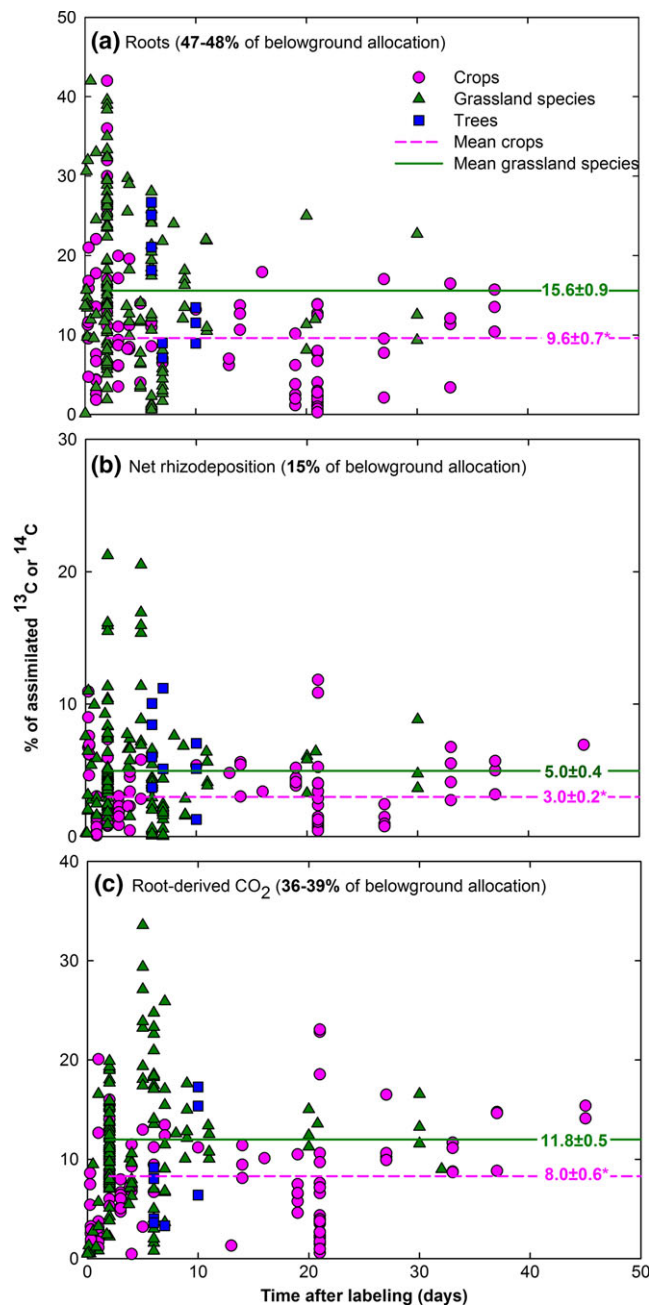

FIGURE 4 Allocation of recently assimilated C as percent of total assimilated $^{13}\text{C}/^{14}\text{C}$ to belowground pools: roots (a), net rhizodeposition (rhizodeposition remaining in soil after microbial utilization) (b) and root-derived CO_2 (c) for crops, grassland species, and trees. Note different y-axis scaling of the three subfigures. The solid lines are the mean values of all data (>1 day after labeling). The asterisk indicates a significant difference ($p < .05$) between the mean values for crops and grasses [Colour figure can be viewed at wileyonlinelibrary.com]

assimilates into harvested parts, mainly into the grains. The lower shoot-to-root ratio of grasses also reflects their higher C storage in roots compared to crops (Table 1). As reviewed by Bolinder, Janzen, Gregorich, Angers, and VandenBygaart (2007), shoot-to-root ratios of annual crops were on average about 5, whereas only 1.3 for grasses. We calculated much higher mean ratios as compared to

TABLE 1 Shoot-to-root ratios, net rhizodeposition-to-root ratios, and root-derived CO_2 -to-root ratios of crops, grassland species and trees. The ratios were calculated as means ($\pm\text{SEM}$) and medians of all collected data after 1 day after labeling. For crops, 20 studies including 99 data sets; for grasses, 16 studies with 128 data sets (note the studies from high montane and wet ecosystems were excluded, i.e., Hafner et al., 2012; Gao et al., 2015; Wu et al., 2010; Zhao et al., 2015); and for trees, three studies with nine data sets were considered

Ratio		Crops	Grasses	Trees
Shoot/Root	Mean	15.0 ± 3.2	5.0 ± 0.6	2.3 ± 0.4
	Median	4.7	2.6	2.0
Net rhizodeposition/Root	Mean	0.5 ± 0.1	0.5 ± 0.1	0.5 ± 0.1
	Median	0.4	0.3	0.4
Root-derived CO_2 /Root	Mean	1.2 ± 0.1	1.3 ± 0.1	0.6 ± 0.1
	Median	0.9	0.8	0.5

Bolinder et al. (2007), because of a few studies with very low allocation of assimilated C to roots (e.g., Keith, Oades, & Martin, 1986; Swinnen, Van Veen, & Merckx, 1994). Moreover, the ratios in our study were determined based on C allocated to shoots and roots, not on dry matter partitioning of plant biomass. Median values for crops and grasses were with 4.7 and 2.6, respectively, in line with the review of Bolinder et al. (2007) (Table 1).

Carbon allocated belowground is lost through rhizodeposition and root respiration. Remus and Augustin (2016) reported highly correlated relationships between root growth, rhizodeposition and root-derived CO_2 . Net C remaining in the roots of crops and grasses averages 10% and 16% (median 9% and 14%) of assimilated C, respectively (Figure 4). Net rhizodeposition accounts for 3% and 5% for crops and grasses, respectively (Figure 4; median 3% and 4%). About 8% and 12% (median 7% and 11%) of assimilated C is lost as root-derived CO_2 from crops and grasses (Figure 4).

Based on our database, we conclude that despite grasses showed higher allocation of C to belowground pools than crops (33% vs. 21%), the proportion of this C (% of C allocated belowground) that remained in roots, in the soil (net rhizodeposition) and is released as CO_2 is equal for crops and grasses (Figure 4) and resulted in similar partitioning ratios (Table 1). In most (>80%) of the reviewed data sets (217 out of 258), the C allocation to roots is higher than to net rhizodeposits (Figure 5). Interestingly, half of the data with net rhizodeposition-to-root ratios larger than one are from montane and alpine pasture ecosystems on the Tibetan Plateau, indicating that grasses are able to adapt their C allocation pattern to extreme environmental conditions (Figure 5). Mean net rhizodeposition-to-root ratios are 0.5 for both crops and grasses and the median is 0.4 and 0.3 for crops and grasses, respectively (Table 1).

The mean partitioning ratio between root-derived CO_2 and root biomass is 1.2 and 1.3 and the median is 0.9 and 0.8 for crops and grasses, respectively, indicating similar allocation between these pools (Table 1). Root-derived CO_2 consists of root respiration as well as microbial decomposition of rhizodeposits (rhizomicrobial CO_2). The separation of root and rhizomicrobial respiration is extremely

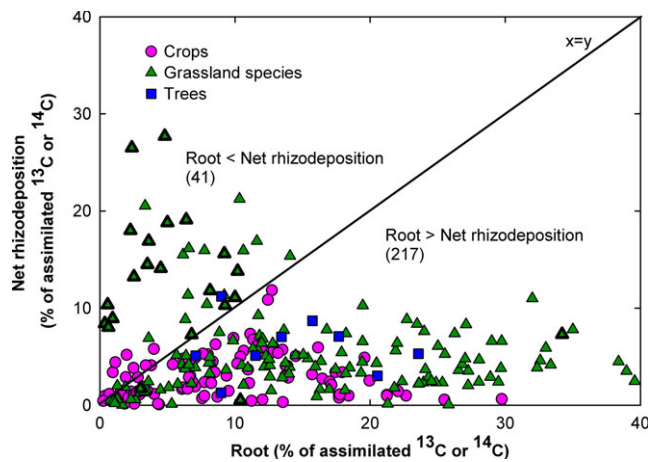

FIGURE 5 Relationship between C allocated to roots and net rhizodeposition as % of total assimilated $^{13}\text{C}/^{14}\text{C}$, from 258 data sets at sampling times >1 day after labeling. For most data sets (217), C allocation to roots exceeded that to net rhizodeposition. Only for 41 data sets was C allocation to net rhizodeposition larger than that to roots. Black triangles are data from studies conducted in montane ecosystems on the Tibetan Plateau (Gao et al., 2015; Hafner et al., 2012; Wu et al., 2010; Zhao et al., 2015)

challenging, as both CO_2 sources are similarly labeled by the applied tracer (Cheng, Coleman, Carroll, & Hoffman, 1993; Kuzyakov, 2005), are located in the same place (rhizosphere) and are produced at nearly the same time. Coupling experiments with modeling, Pausch, Tian, Riederer, and Kuzyakov (2013) showed that more than 60% of the gross rhizodeposition of maize is lost as CO_2 within 16 days through microbial decomposition. Therefore, the percentage of rhizodeposits remaining in soil (net rhizodeposition) greatly underestimates gross rhizodeposition, because of very fast microbial decomposition. Gross rhizodeposition needs to be considered, because it fuels the microbial life in soil, structures microbial communities in the rhizosphere (Pausch et al., 2016), and is a very important part of short-term C cycling within the plant–soil–microorganism–atmosphere system. The percentage of assimilated ^{13}C or ^{14}C remaining in microbial biomass is low, averaging 1.4% across all plant groups (Table 2). However, the percentage of C remaining in a pool does not reflect the flux of C passing through this pool, which can be much larger.

In summary, despite the low percentage of assimilates retained in microbial biomass C ($<1.5\%$), rhizodeposits are a major driver of microbially mediated processes in soil, and more than half is utilized by microorganisms within a few days (Pausch et al., 2013). Therefore, the importance of these processes cannot be evaluated solely on the basis of the resulting pools (the most commonly measured parameters), but fluxes (total amount of C passing through a pool) should also be considered.

3.1.2 | Allocation velocity

Strong negative correlations between C allocation to shoots and to roots clearly reflect translocation of C from shoots to roots of crops

and grasses (Figure 6). Allocation rates from shoots to belowground pools are highest within the first day after pulse labeling, resulting in distinct correlations between shoot ^{13}C or ^{14}C and root ^{13}C or ^{14}C for sampling within the first day (Figure 6, dashed lines) and sampling later than the first day after labeling (Figure 6, solid lines). Strong changes in allocation during the first day cause highly time-dependent partitioning of C pools and fluxes. In conclusion, to determine reliable partitioning pattern, the allocation from the shoot to belowground pools should be nearly completed and shoot respiration of the assimilated ^{13}C or ^{14}C should be mostly finished. Therefore, in studies on allocation pattern, dynamic sampling after pulse labeling is inevitable.

Belowground allocation of assimilates is a very fast process. All studies with samplings shorter than 1 day showed very fast C allocation rates (Table S1). Already within the first few hours, labeled C was detected in rhizodeposits and root-derived CO_2 (e.g., Domanski, Kuzyakov, Siniakina, & Stahr, 2001; Riederer, Pausch, Kuzyakov, & Foken, 2015; Tian et al., 2013). After 10 hr, about 21% of recent assimilates are allocated belowground by crops and grasses. This rapid transport implies only a very short time lag between photosynthesis and the response of the rhizosphere processes to allocated assimilates.

The half-life of soluble assimilates in the shoots, before they are translocated to other pools, used for respiration or incorporated into structural compounds (e.g., lignin, cellulose, hemicellulose), is about twice as long (28 hr) for crops as for grasses (15 hr). The mean residence time (MRT) of soluble assimilates in the shoots is 41 and 22 hr for crops and grasses, respectively (Figure 3, bottom).

3.2 | Factors affecting C allocation belowground

The mechanisms of assimilate partitioning by plants have not been resolved, and “push”, “pull” and “shared control” hypotheses have been developed (Farrar & Jones, 2000). Carbon allocation belowground, and especially rhizodeposition, is influenced by various biotic and abiotic factors in the plant–soil system (Jones et al., 2004). The soil environment affects rhizodeposition and especially root exudation through physical and chemical conditions, as well as through the activity, composition and functional diversity of microbial populations, plant growth promoting bacteria, mycorrhizal fungi, and phytopathogens (Lynch, Brimecombe, & de Leij, 2002). On the other hand, plant factors such as species and development stage impact on the amount and composition of rhizodeposits (Cheng, Johnson, & Fu, 2003; Kuzyakov, 2002; Van der Krift, Kuikman, Möller, & Berendse, 2001; Vancura, 1964). Moreover, the C supply to rhizosphere processes via exudation depends to a large extent on the intensity of photosynthesis, and thus on such controlling factors as atmospheric CO_2 concentration, N content, light intensity, and soil moisture (Craine, Wedin, & Chapin, 1999; Kuzyakov, 2002; Kuzyakov & Cheng, 2001).

Three main factors influencing C allocation belowground are discussed here: plant age, N fertilization, and elevated atmospheric CO_2 . Other factors also had significant effects on belowground C

TABLE 2 Carbon incorporation into microbial biomass as percentage of total plant-assimilated ¹⁴C

Study #	Reference ^a	Species	Plant age at the time of labeling [DAS]	Sampling [DAL]	Microbial biomass C [% of TAC]
3	Tian et al. (2013) ^b	<i>Oryza sativa</i>	35	0.25	6.65
	Tian et al. (2013) ^b	<i>Oryza sativa</i>	35	2	2.22
	Tian et al. (2013) ^b	<i>Oryza sativa</i>	35	6	1.20
	Tian et al. (2013) ^b	<i>Oryza sativa</i>	35	14	0.96
	Tian et al. (2013) ^b	<i>Oryza sativa</i>	35	33	1.06
	Tian et al. (2013) ^b	<i>Oryza sativa</i>	35	37	0.86
	Tian et al. (2013) ^b	<i>Oryza sativa</i>	35	45	1.14
21	Sanallah et al. (2012) ^b	<i>Lolium perenne</i>	40	5	1.78
	Sanallah et al. (2012) ^b	<i>Festuca arundinacea</i>	40	5	2.03
	Sanallah et al. (2012) ^b	<i>Medicago sativa</i>	40	5	1.07
	Sanallah et al. (2012) ^b	<i>Lolium perenne</i> , <i>Festuca arundinacea</i> , <i>Medicago sativa</i>	40	5	1.71
22	Allard et al. (2006) ^b	<i>Lolium perenne</i>	88	2	0.28
	Allard et al. (2006) ^b	<i>Lolium perenne</i>	92	2	0.46
24	Griffiths et al. (1998) ^b	<i>Lolium perenne</i>	28 DAG	6	0.09
43	Mikan, Zak, Kubiske, and Pregitzer (2000) ^b	<i>Populus tremuloides</i>	2 years	6	0.45
Mean					1.40
Median					0.95

DAS, Days after sowing; DAG, Days after germination; DAL, Days after labeling; TAC, Total assimilated C.

^aStudies were performed under controlled conditions with ¹⁴C pulse labeling.

^bAverage across treatments.

allocation or rhizodeposition in individual studies. However, because these factors have only been investigated in a small number of studies, with much variation in experimental conditions between the studies, no generalizations about these other factors are possible at this stage.

3.2.1 | Plant age

During early phases of fast vegetative growth, plants have higher root-to-shoot ratios than older plants (Amos & Walters, 2006). Young plants allocate more C to roots, whereas older plants preferentially allocate the newly assimilated C to the shoots (Gregory & Atwell, 1991; Keith et al., 1986; Palta & Gregory, 1997). This results in reduced exudation per unit root biomass in older plants (reviewed by Nguyen, 2003; Pausch et al., 2013). However, the contribution of dying roots to rhizodeposition increases with plant aging.

The dynamics of assimilate allocation to belowground pools over plant development differ greatly between crops and grasses, with much longer periods of belowground allocation for grasses (Figure 7). For crops, the maximal belowground allocation occurs within 50 days after planting and drops sharply thereafter. Grasses showed a strong increase within the first 100 days and only a gradual decline

thereafter. The high C allocation and storage belowground over all development stages is essential for survival of perennials during unfavorable season (Warembourg & Estelrich, 2001).

3.2.2 | N fertilization

Above and belowground allocation strongly depends on the availability of nutrients in soil (Farrar & Jones, 2000). Allocation of newly assimilated C to belowground pools is negatively correlated with the amount of mineral N, and so, with N fertilization (exemplified here by three studies with *Lolium perenne*, Figure 8). High N availability reduces the portion of C allocated belowground and rhizodeposition, hence relatively more C remains in shoots for aboveground biomass production (Phillips, Finzi, & Bernhardt, 2011). This is consistent with the resource optimization hypothesis that increasing nutrient availability reduces the C costs of nutrient acquisition (Ågren & Franklin, 2003; Farrar & Jones, 2000).

3.2.3 | Elevated atmospheric CO₂

Elevated atmospheric CO₂ increases plant photosynthesis by 10%–20% (Ainsworth & Long, 2004; Zak, Pregitzer, King, & Holmes, 2000). Total C allocated belowground depends on photosynthetic

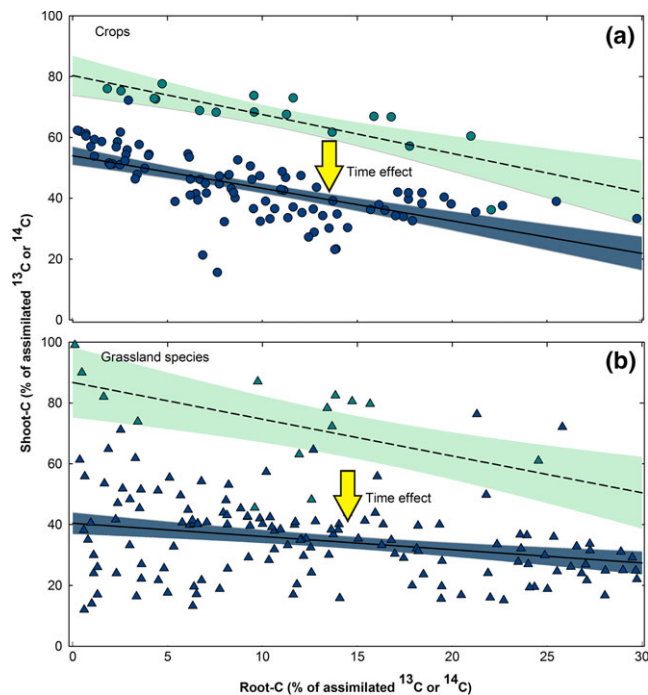

FIGURE 6 Correlation between the allocation of recently assimilated C to shoots and to roots for crops (a) and grassland species (b). The green symbols are results from pulse labeling studies where samples were taken within the first day after labeling. The blue symbols indicate results from sampling times later than 1 day after labeling. Statistics are provided in Table S2. The filled areas indicate 95% confidence bands. The arrows show the effect of time after labeling on the regression line and so, on the allocation of assimilated C from shoots to roots

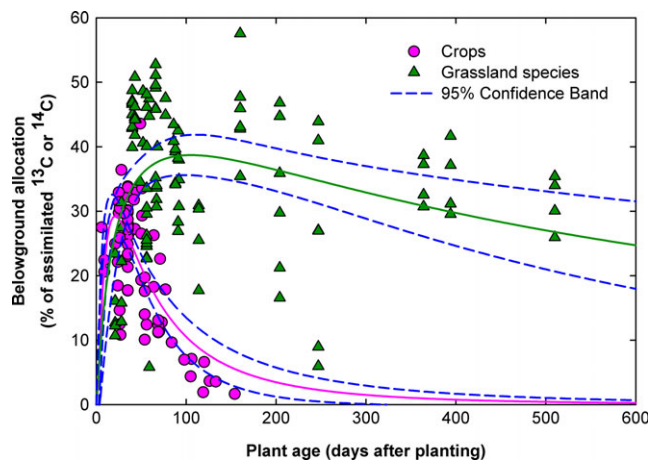

FIGURE 7 Total ¹³C or ¹⁴C allocation of recent assimilates to all belowground pools for crops and grassland species depending on plant age (labeling was performed on single plant species of different age). A peak equation (log normal, 3 parameters) was fitted. Statistics are provided in Table S3. Dashed lines indicate 95% confidence bands. Data from sampling dates >1 day after labeling are shown

intensity. Grasses have short time lags of only 12.5 hr between photosynthesis and CO₂ release from the soil (Kuziyakov & Gavrichkova, 2010; Pausch & Kuziyakov, 2011). Thus, belowground C

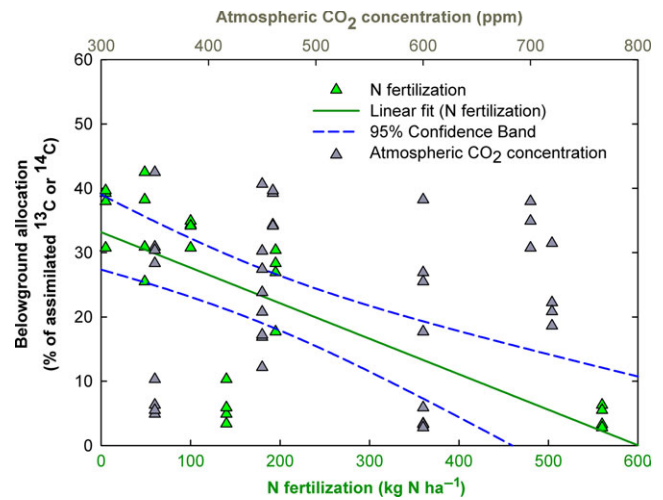

FIGURE 8 Total ¹³C or ¹⁴C allocation of recent assimilates to all belowground pools depending on N fertilization (bottom x-axis) and atmospheric CO₂ concentration (top x-axis). Results of three N fertilization studies (24 sets of partitioning coefficients) with *Lolium perenne* are shown (Allard, Robin, Newton, Lieffering, & Soussana, 2006; Bazot, Ulf, Blum, Nguyen, & Robin, 2006; Hill et al., 2007). A linear curve ($y = a + bx$) was fitted through the data points for belowground C allocation. For total belowground C, $a = 33.2 \pm 2.8$ ($p < .0001$) and $b = -0.06 \pm 0.01$ ($p < .0001$), $R^2 = 0.53$. Dashed lines indicate 95% confidence bands. Results of six studies with variation in atmospheric CO₂ concentration (36 sets of partitioning coefficients) with *Lolium perenne* are shown (Allard et al., 2006; Bazot et al., 2006; Griffiths, Ritz, Ebbelwhite, Paterson, & Killham, 1998; Hill et al., 2007; Paterson et al., 1999; Rattray, Paterson, & Killham, 1995)

allocation, the release of exudates and CO₂ efflux from the soil are largely governed by photosynthesis and, in turn, by atmospheric CO₂ concentration (Craine et al., 1999; Kuziyakov, 2002; Kuziyakov & Cheng, 2001). It should, however, be noted that other factors may gain greater importance, such as insufficient nutrient availability for plant growth or altered rhizodeposits quality under elevated CO₂ and high plant biomass production (De Graaff, Van Groenigen, Six, Hungate, & Van Kessel, 2006; Paterson, Rattray, & Killham, 1996).

With higher plant growth under elevated CO₂, the absolute amount of assimilate as well as the portion allocated to rhizodeposition increases. Paterson et al. (1996) reported increases in assimilate allocation to the rhizosphere of *Triticum aestivum* and *L. perenne* of 19% and 62%, respectively, under elevated CO₂. Cheng and Johnson (1998) reported a 60% increase in soluble C concentration in the wheat rhizosphere. Assessment of absolute C input into the rhizosphere is needed because higher input and altered quality of rhizodeposits alter C cycling through changing enzyme activities (Dorodnikov et al., 2009), microbial growth (Blagodatskaya, Blagodatsky, Dorodnikov, & Kuziyakov, 2010) and SOM decomposition (Cheng & Johnson, 1998).

However, higher absolute and relative allocation to belowground pools and fluxes does not necessarily change the relative partitioning

of assimilate among belowground pools, and hence, does not necessarily affect C partitioning belowground.

3.3 | Estimation of absolute net rhizodeposition pools and fluxes

3.3.1 | Pools: Estimation of rhizodeposition based on root sampling

As shown in the previous sections, C allocation strongly depends on experimental/environmental conditions as well as on plant properties. Despite the variability of the net rhizodeposition-to-root ratio, it allows a rough estimation of net rhizodeposition on field scale. Root biomass C of annual cereal crops (wheat, barley, oat, triticale) is 36–67.5 g C m⁻² (calculated with a plant C content of 45% dry weight; Bolinder et al., 2007; Jackson et al., 1996; Robinson, 2007). Therefore, the annual net C input via rhizodeposition, calculated based on the rhizodeposition-to-root ratio of 0.5, is 18–34 g C m⁻². This assessment corresponds well to a recent labeling experiment under field conditions, where net C input by maize rhizodeposition amounted to 17 g C m⁻² (Pausch et al., 2013).

The largest uncertainty of this approach is that it is based on root sampling and does not consider root turnover during the vegetation period: it accounts only for the roots present at the sampling time (usually at harvest). This means that the roots (mainly fine roots) decomposed during the vegetation period are not included in

the calculation of rhizodeposition, and so total C input is underestimated. This relates to the problem that the measured pools (here: roots) do not reflect the fluxes (Kuzuyakov, 2011).

3.3.2 | Pools and Fluxes: Assessment of rhizodeposition using eddy-covariance measurements

Total belowground C allocation (including roots) can also be assessed with the partitioning results generalized in this review and gross primary production (GPP) data obtained from atmospheric flux measurements (Figure 9). The generalized partitioning was obtained based on the broad range of pulse labeling experiments. Single pulse labeling experiments do not provide data that can be easily extrapolated to a whole growing season. However, the results generalized based on our large database consider the temporal scales of GPP and C allocation after labeling (Riederer et al., 2015). Therefore, these generalized partitioning values of C allocation belowground can be applied to GPP data to upscale the studies with individual plants on the field and ecosystem levels.

As examples for annual mean GPP, we used the FLUXNET data for crops published by Falge, Baldocchi et al. (2002) and for grasslands by Riederer et al. (2015). The agricultural field in Denmark (55°29'N, 11°39'E) was cropped with wheat and CO₂ fluxes were measured by eddy-covariance (Falge, Tenhunen et al., 2002). For grasslands, a submontane extensively managed site in Germany was selected (50°05'25"N, 11°51'25"E), with the dominant species

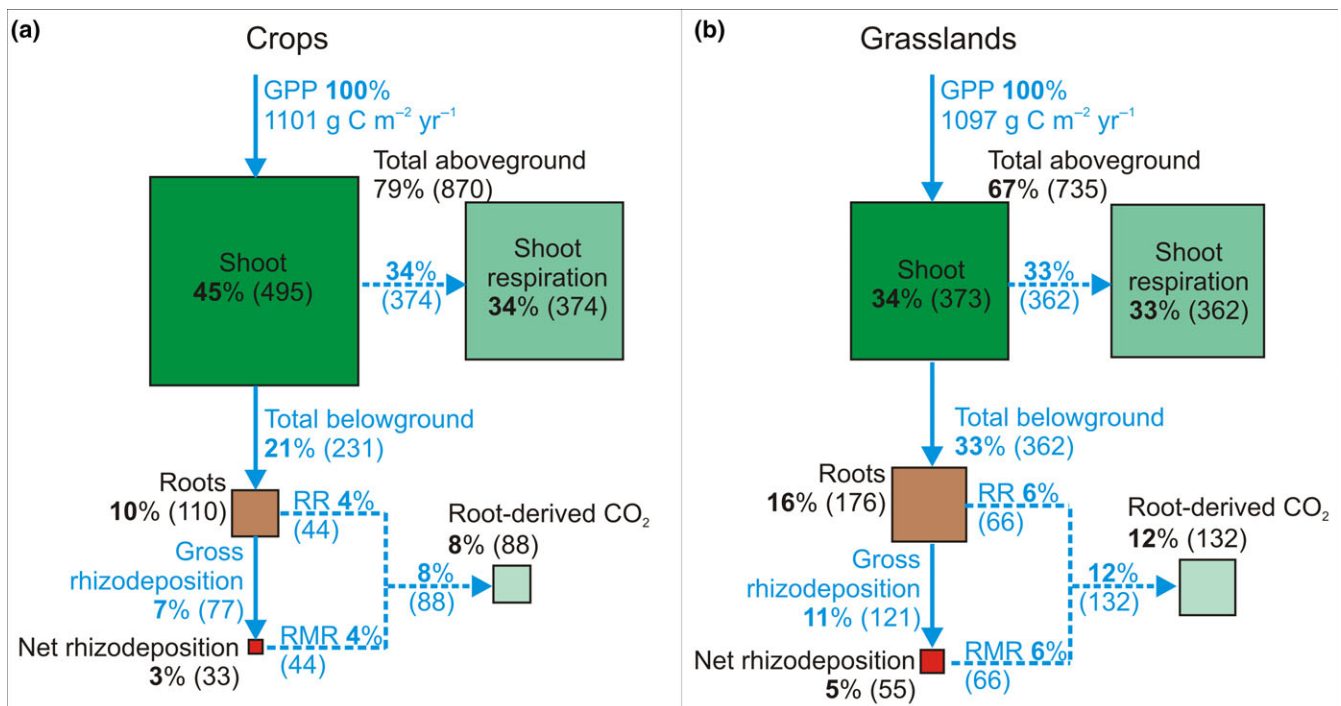

FIGURE 9 Overview and examples of C allocation patterns for crops and grassland species. Percentage values (generalization) shown were calculated as averages of all collected data (>1 day after labeling) according to Figures 3 and 4. For crops, 20 studies including 99 data sets, and for grassland species, 16 studies with 128 data sets were used. Based on gross primary production (GPP), absolute values of C partitioning (examples) for crops and grasslands are shown in parentheses (g C m⁻² year⁻¹). The GPP data for crops were taken from Falge, Baldocchi et al. (2002) and for grasslands from Riederer et al. (2015)

Alchemilla monticola, *Juncus filiformis*, *Polygonum bistorta*, *Ranunculus acris*, and *Trifolium repens* (Riederer et al., 2015).

Based on the C budget, not only C pools but also hidden fluxes can be considered (Figure 9). In the example (Falge, Baldocchi et al., 2002), crops allocated total $231 \text{ g C m}^{-2} \text{ year}^{-1}$ belowground. About $110 \text{ g C m}^{-2} \text{ year}^{-1}$ remained in the roots. Hence, the root C estimated based on GPP and partitioning data is higher ($43 \text{ g C m}^{-2} \text{ year}^{-1}$ as compared to maximum value of root biomass sampling) as compared to the data from root biomass sampling (see section 3.3.1). We assume that this difference corresponds to root turnover. More than 50% of C allocated belowground was transferred through the roots and respired or allocated to rhizodeposition. The flux of gross rhizodeposition from the roots into the soil can be assessed by assuming an equal contribution of root respiration and rhizomicrobial respiration to root-derived CO_2 (see section 3.1.2; Cheng et al., 1993; Pausch et al., 2013). Based on this assumption, we conclude that in this example, gross rhizodeposition of crops accounted for $77 \text{ g C m}^{-2} \text{ year}^{-1}$, while net rhizodeposition was only $33 \text{ g C m}^{-2} \text{ year}^{-1}$, i.e., on average more than 55% of gross rhizodeposition was decomposed to CO_2 (Figure 9).

Gross primary production in the grassland was $1097 \text{ g C m}^{-2} \text{ year}^{-1}$ (Riederer et al., 2015). Thus, the flux of rhizodeposition (gross rhizodeposition) from roots into the soil was $121 \text{ g C m}^{-2} \text{ year}^{-1}$. The pool of rhizodeposits remaining in the soil (net rhizodeposition) was, however, only $55 \text{ g C m}^{-2} \text{ year}^{-1}$. Riederer et al. (2015) used $^{13}\text{CO}_2$ pulse labeling in the field to partition C pools. The partitioning results correspond very well to the generalized data and ratios between pools for grasslands calculated in this review. In addition, based on the partitioning results together with ecosystem flux measurements, known ecosystem respiration (R_{ECO}) can be partitioned (i) into aboveground respiration and CO_2 efflux from soil, and (ii) CO_2 efflux from soil can be partitioned into root- and SOM-derived CO_2 .

Overall, the generalization in this review can be applied for a broad range of applications to estimate C pools and fluxes into various compartments of the plant–soil–microorganisms–atmosphere system and to upscale rhizodeposition to the ecosystem level.

4 | CONCLUSIONS

Carbon input by plants into the soil is a major flux in the global C cycle and is crucial not only for C sequestration, but also for maintenance of soil fertility, ecosystem stability, and functions. Rhizodeposition — the release of organic compounds into the soil by living roots — remains the most uncertain part of this C flux, and of the C cycle.

More than two-thirds of assimilates remain aboveground and are used for shoot biomass production and respiration. Assimilates are allocated very fast to roots — mainly within the first day. The dynamics of belowground C allocation depend strongly on plant age and differ between crops and grassland species. Annual crops have a much shorter period of belowground C allocation over the growth period

(maximum occurs within 2 months) compared to grasses (maximum between 50 and 200 days with very slow decline thereafter). This fast, preferential C allocation by cereals to aboveground biomass reflects the long-term selection of crops for yield maximization. On the other hand, grasses are mainly perennials, which rely on C reserves for regrowth in spring or after grazing or mowing and hence, show higher and longer C allocation to belowground pools.

The generalizations of C partitioning can be applied to root biomass or to atmospheric flux measurements (gross primary production, ecosystem respiration, CO_2 efflux from soil) to obtain absolute C allocation to various pools and fluxes within plant–soil–microorganisms–atmosphere systems as well as for upscaling from plot to ecosystem levels.

ACKNOWLEDGEMENTS

We would like to thank Kyle Mason-Jones for suggestions on the earlier version of the manuscript. Both authors are very thankful for the long-term support by Deutsche Forschungsgemeinschaft (DFG) within various projects investigating belowground C allocation by plants, root–microbial interactions, rhizodeposition and microbial transformation of rhizodeposits. The authors would also like to thank two anonymous reviewers for their valuable suggestions and recommendations.

REFERENCES

- Ågren, G. I., & Franklin, O. (2003). Root:shoot ratios, optimization and nitrogen productivity. *Annals of Botany*, *92*, 795–800.
- Ainsworth, E. A., & Long, S. P. (2004). What have we learned from 15 years of free-air CO_2 enrichment (FACE)? A meta-analytic review of the responses of photosynthesis, canopy properties and plant production to rising CO_2 . *New Phytologist*, *165*, 351–372.
- Allard, V., Robin, C., Newton, P. C. D., Lieffering, M., & Soussana, J. F. (2006). Short and long-term effects of elevated CO_2 on *Lolium perenne* rhizodeposition and its consequences on soil organic matter turnover and plant N yield. *Soil Biology and Biochemistry*, *38*, 1178–1187.
- Amos, B., & Walters, D. T. (2006). Maize root biomass and net rhizodeposited carbon: An analysis of the literature. *Soil Science Society of America Journal*, *70*, 1489–1503.
- Bazot, S., Uff, L., Blum, H., Nguyen, C., & Robin, C. (2006). Effects of elevated CO_2 concentration on rhizodeposition from *Lolium perenne* grown on soil exposed to 9 years of CO_2 enrichment. *Soil Biology and Biochemistry*, *38*, 729–736.
- Blagodatskaya, E., Blagodatsky, S., Dorodnikov, M., & Kuzyakov, Y. (2010). Elevated atmospheric CO_2 increases microbial growth rates in soil: Results of three CO_2 enrichment experiments. *Global Change Biology*, *16*, 836–848.
- Bolinder, M. A., Janzen, H. H., Gregorich, E. G., Angers, D. A., & VandenBygaart, A. J. (2007). An approach for estimating net primary productivity and annual carbon input into the soil for common agricultural crops in Canada. *Agriculture, Ecosystems and Environment*, *118*, 29–42.
- Cheng, W., Coleman, D. C., Carroll, R., & Hoffman, C. A. (1993). In situ measurement of root respiration and soluble C concentrations in the rhizosphere. *Soil Biology and Biochemistry*, *25*, 1189–1196.
- Cheng, W., & Johnson, D. W. (1998). Elevated CO_2 , rhizosphere processes, and soil organic matter decomposition. *Plant and Soil*, *202*, 167–174.

- Cheng, W., Johnson, D. W., & Fu, S. (2003). Rhizosphere effects on decomposition: Controls of plant species, phenology, and fertilization. *Soil Science Society of America Journal*, *67*, 1418–1427.
- Craine, J. M., Wedin, D. A., & Chapin, F. S. (1999). Predominance of eco-physiological controls on soil CO₂ flux in a Minnesota grassland. *Plant and Soil*, *207*, 77–86.
- De Graaff, M.-A., Van Groenigen, K.-J., Six, J., Hungate, B., & Van Kessel, C. (2006). Interaction between plant growth and soil nutrient cycling under elevated CO₂: A meta-analysis. *Global Change Biology*, *12*, 2077–2091.
- Dennis, P. G., Miller, A. J., & Hirsch, P. R. (2010). Are root exudates more important than other sources of rhizodeposits in structuring rhizosphere bacterial communities? *FEMS Microbial Ecology*, *72*, 313–327.
- Domanski, G., Kuzyakov, Y., Siniakina, S. V., & Stahr, K. (2001). Carbon flows in the rhizosphere of ryegrass (*Lolium perenne*). *Journal of Plant Nutrition and Soil Science*, *164*, 381–387.
- Dorodnikov, M., Blagodatskaya, E., Blagodatsky, S., Marhan, S., Fangmeier, A., & Kuzyakov, Y. (2009). Stimulation of microbial extracellular enzyme activities by elevated CO₂ depends on soil aggregate size. *Global Change Biology*, *15*, 1603–1614.
- Epron, D., Bahn, M., Derrien, D., Lattanzi, F. A., Pumpanen, J., Gessler, A., ... Buchmann, N. (2012). Pulse-labelling trees to study carbon allocation dynamics: A review of methods, current knowledge and future prospects. *Tree Physiology*, *32*, 776–798.
- Falge, E., Baldocchi, D., Tenhunen, J., Aubinet, M., Bakwin, P., Berbigier, P., ... Wofsy, S. (2002). Seasonality of ecosystem respiration and gross primary production as derived from FLUXNET measurements. *Agricultural and Forest Meteorology*, *113*, 53–74.
- Falge, E., Tenhunen, J., Baldocchi, D., Aubinet, M., Bakwin, P., Berbigier, P., ... Wofsy, S. (2002). Phase and amplitude of ecosystem carbon release and uptake as derived from FLUXNET measurements. *Agricultural and Forest Meteorology*, *113*, 75–95.
- Farrar, J. F., & Jones, D. L. (2000). The control of carbon acquisition by roots. *New Phytologist*, *147*, 43–53.
- Fischer, H., Ingwersen, J., & Kuzyakov, Y. (2010). Microbial uptake of low-molecular-weight organic substances out-competes sorption in soil. *European Journal of Soil Science*, *61*, 504–513.
- Gao, J.-Q., Gao, J.-J., Zhang, X.-W., Xu, X.-L., Deng, Z.-H., & Yu, F.-H. (2015). Effects of waterlogging on carbon assimilate partitioning in the Zoigê alpine wetlands revealed by ¹³CO₂ pulse labeling. *Scientific Reports*, *5*, 9411. <https://doi.org/10.1038/srep09411>
- Grayston, S. J., Vaughan, D., & Jones, D. L. (1996). Rhizosphere carbon flow in trees, in comparison with annual plants: The importance of root exudation and its impact on microbial activity and nutrient availability. *Applied Soil Ecology*, *5*, 29–56.
- Gregory, P. J., & Atwell, B. J. (1991). The fate of carbon in pulse-labelled crops of barley and wheat. *Plant and Soil*, *136*, 205–213.
- Griffiths, B. S., Ritz, K., Ebbelwhite, N., Paterson, E., & Killham, K. (1998). Ryegrass rhizosphere microbial community structure under elevated carbon dioxide concentrations, with observations on wheat rhizosphere. *Soil Biology and Biochemistry*, *30*, 315–321.
- Hafner, S., Unteregelsbacher, S., Seeber, E., Becker, L., Xu, X., Li, X., ... Kuzyakov, Y. (2012). Effect of grazing on carbon stocks and assimilate partitioning in a Tibetan montane pasture revealed by ¹³CO₂ pulse labeling. *Global Change Biology*, *18*, 528–538.
- Hill, P. W., Marshall, C., Williams, G. C., Blum, H., Harmens, H., Jones, D. L., & Farrar, J. F. (2007). The fate of photosynthetically-fixed carbon in *Lolium perenne* grassland as modified by elevated CO₂ and sward management. *New Phytologist*, *173*, 766–777.
- Hütsch, B. W., Augustin, J., & Merbach, W. (2002). Plant rhizodeposition - an important source for carbon turnover in soils. *Journal of Plant Nutrition and Soil Science*, *165*, 397–407.
- Jackson, R. B., Canadell, J., Ehleringer, J. R., Mooney, H. A., Sala, O. E., & Schulze, E. D. (1996). A global analysis of root distributions for terrestrial biomes. *Oecologia*, *108*, 389–411.
- Jones, D. L., Hodge, A., & Kuzyakov, Y. (2004). Plant and mycorrhizal regulation of rhizodeposition. *New Phytologist*, *163*, 459–480.
- Jones, D. L., Nguyen, C., & Finlay, R. D. (2009). Carbon flow in the rhizosphere: Carbon trading at the soil-root interface. *Plant and Soil*, *321*, 5–33.
- Keith, H., Oades, J. M., & Martin, J. K. (1986). Input of carbon to soil from wheat plants. *Soil Biology and Biochemistry*, *18*, 445–449.
- Kögel-Knabner, I. (2002). The macromolecular organic composition of plant and microbial residues as inputs to soil organic matter. *Soil Biology and Biochemistry*, *34*, 139–162.
- Kuzyakov, Y. (2002). Review: Factors affecting rhizosphere priming effects. *Journal of Plant Nutrition and Soil Science*, *165*, 382–396.
- Kuzyakov, Y. (2005). Theoretical background for partitioning of root and rhizomicrobial respiration by $\delta^{13}\text{C}$ of microbial biomass. *European Journal of Soil Biology*, *4*, 1–9.
- Kuzyakov, Y. (2011). How to link soil C pools with CO₂ fluxes? *Biogeochemistry*, *8*, 1523–1537.
- Kuzyakov, Y., & Blagodatskaya, E. (2015). Microbial hotspots and hot moments in soil: Concept & review. *Soil Biology and Biochemistry*, *83*, 184–199.
- Kuzyakov, Y., & Cheng, W. (2001). Photosynthesis controls of rhizosphere respiration and organic matter decomposition. *Soil Biology and Biochemistry*, *33*, 1915–1925.
- Kuzyakov, Y., & Domanski, G. (2000). Carbon input by plants into the soil. Review. *Journal of Plant Nutrition and Soil Science*, *163*, 421–431.
- Kuzyakov, Y., & Gavrichkova, O. (2010). Time lag between photosynthesis and carbon dioxide efflux from soil: A review of mechanisms and controls. *Global Change Biology*, *16*, 3386–3406.
- Kuzyakov, Y., & Schneckenberger, K. (2004). Review of estimation of plant rhizodeposition and their contribution to soil organic matter formation. *Archives of Agronomy and Soil Science*, *50*, 115–132.
- Lal, R. (2008). Sequestration of atmospheric CO₂ in global carbon pools. *Energy and Environmental Science*, *1*, 86–100.
- Lynch, J. M., Brimecombe, M. J., & de Leij, F. A. A. M. (2002). *Rhizosphere*. Chichester: John Wiley & Sons, Ltd. <https://doi.org/10.1002/9780470015902.a0000403.pub2>
- Meharg, A. A. (1994). A critical review of labelling techniques used to quantify rhizosphere carbon flow. *Plant and Soil*, *166*, 55–62.
- Mikan, C. J., Zak, D. R., Kubiske, M. E., & Pregitzer, K. S. (2000). Combined effects of atmospheric CO₂ and N availability on the below-ground carbon and nitrogen dynamics of aspen mesocosms. *Oecologia*, *124*, 432–445.
- Moradi, A. B., Carminati, A., Lamparter, A., Woche, S. K., Bachmann, J., Vetterlein, D., ... Oswald, S. E. (2012). Is the rhizosphere temporarily water repellent? *Vadose Zone Journal*, *11*. <https://doi.org/10.2136/vzj2011.0120>
- Neumann, G., & Römheld, V. (2007). The release of root exudates as affected by the plant physiological status. In R. Pinton, Z. Varanini, & P. Nannipieri (Eds.), *The Rhizosphere. Biochemistry and organic substances at the soil-plant interface* (pp. 23–72). Boca Raton: CRC Press.
- Nguyen, C. (2003). Rhizodeposition of organic C by plant: Mechanisms and controls. *Agronomie*, *23*, 375–396.
- Palta, J. A., & Gregory, P. J. (1997). Drought affects the fluxes of carbon to roots and soil in ¹³C pulse-labelled plants of wheat. *Soil Biology and Biochemistry*, *29*, 1395–1403.
- Paterson, E. (2003). Importance of rhizodeposition in the coupling of plant and microbial productivity. *European Journal of Soil Science*, *54*, 741–750.
- Paterson, E., Gebbing, T., Abel, C., Sim, A., & Telfer, G. (2007). Rhizodeposition shapes rhizosphere microbial community structure in organic soil. *New Phytologist*, *173*, 600–610.
- Paterson, E., Hodge, A., Thornton, B., Millard, P., & Killham, K. (1999). Carbon partitioning and rhizosphere C-flow in *Lolium perenne* as affected by CO₂ concentration, irradiance and below-ground conditions. *Global Change Biology*, *5*, 669–678.

- Paterson, E., Midwood, A. J., & Millard, P. (2009). Through the eye of the needle: A review of isotope approaches to quantify microbial processes mediating soil carbon balance. *New Phytologist*, *184*, 19–33.
- Paterson, E., Rattray, E. A. S., & Killham, K. (1996). Effect of elevated atmospheric CO₂ concentration on C-partitioning and rhizosphere C-flow for three plant species. *Soil Biology and Biochemistry*, *28*, 195–201.
- Paterson, E., Thornton, B., Midwood, A. J., & Sim, A. (2005). Defoliation alters the relative contributions of recent and non-recent assimilate to root exudation from *Festuca rubra*. *Plant, Cell and Environment*, *28*, 1525–1533.
- Pausch, J., Kramer, S., Scharroba, A., Scheunemann, N., Butenschoen, O., Kandeler, E., ... Ruess, L. (2016). Small but active – pool size does not matter for carbon incorporation in below-ground food webs. *Functional Ecology*, *30*, 479–789.
- Pausch, J., & Kuzyakov, Y. (2011). Photoassimilates allocation and dynamics of hotspots in roots visualized by ¹⁴C phosphor imaging. *Journal of Plant Nutrition and Soil Science*, *174*, 12–19.
- Pausch, J., Tian, J., Riederer, M., & Kuzyakov, Y. (2013). Estimation of rhizodeposition at field scale: Upscaling of a ¹⁴C labeling study. *Plant and Soil*, *364*, 273–285.
- Phillips, R. P., Finzi, A. C., & Bernhardt, E. S. (2011). Enhanced root exudation induces microbial feedbacks to N cycling in a pine forest under long-term CO₂ fumigation. *Ecology Letters*, *14*, 187–194.
- Rattray, E. A. S., Paterson, E., & Killham, K. (1995). Characterisation of the dynamics of C-partitioning within *Lolium perenne* and to the rhizosphere microbial biomass using ¹⁴C pulse chase. *Biology and Fertility of Soils*, *19*, 280–286.
- Remus, R., & Augustin, J. (2016). Dynamic linking of ¹⁴C partitioning with shoot growth allows a precise determination of plant-derived C input to soil. *Plant and Soil*, *408*, 493–513.
- Riederer, M., Pausch, J., Kuzyakov, Y., & Foken, T. (2015). Partitioning NEE for absolute C input into various ecosystem pools by combining results from eddy-covariance, atmospheric flux partitioning and ¹³CO₂ pulse labeling. *Plant and Soil*, *390*, 61–76.
- Robinson, D. (2007). Implications of a large global root biomass for carbon sink estimates and for soil carbon dynamics. *Proceedings of the Royal Society of London B: Biological Sciences*, *274*, 2753–2759.
- Sanauallah, M., Chabbi, A., Rumpel, C., & Kuzyakov, Y. (2012). Carbon allocation in grassland communities under drought stress followed by ¹⁴C pulse labeling. *Soil Biology and Biochemistry*, *55*, 132–139.
- Schlesinger, W. (1997). The global carbon cycle. In W. Schlesinger (Ed.), *Biogeochemistry: An analysis of global change* (pp. 358–382). San Diego: Academic press.
- Schleuss, P.-M., Heitkamp, F., Sun, Y., Miede, G., Xu, X., & Kuzyakov, Y. (2015). Nitrogen uptake in an alpine *Kobresia* pasture on the Tibetan Plateau: Localization by ¹⁵N labeling and implications for a vulnerable ecosystem. *Ecosystems*, *18*, 946–957.
- Schmitt, A., Pausch, J., & Kuzyakov, Y. (2013). Effect of clipping and shading on C allocation and fluxes in soil under ryegrass and alfalfa estimated by ¹⁴C labeling. *Applied Soil Ecology*, *64*, 228–236.
- Six, J., Bossuyt, H., Degryze, S., & Deneff, K. (2004). A history of research on the link between (micro)aggregates, soil biota, and soil organic matter dynamics. *Soil and Tillage Research*, *79*, 7–31.
- Swinnen, J., Van Veen, J. A., & Merckx, R. (1994). ¹⁴C pulse-labelling of field-grown spring wheat: An evaluation of its use in rhizosphere carbon budget estimations. *Soil Biology and Biochemistry*, *26*, 161–170.
- Tian, J., Pausch, J., Fan, M., Li, X., Tang, Q., & Kuzyakov, Y. (2013). Allocation and dynamics of assimilated carbon in rice-soil system depending on water management. *Plant and Soil*, *363*, 273–285.
- Van der Krift, T., Kuikman, P. J., Möller, F., & Berendse, F. (2001). Plant species and nutritional-mediated control over rhizodeposition and root decomposition. *Plant and Soil*, *228*, 191–200.
- Vancura, V. (1964). Root exudates of plants. I. Analysis of root exudates of barley and wheat in their initial phases of growth. *Plant and Soil*, *21*, 231–248.
- Warembourg, F. R., & Estelrich, H. D. (2001). Plant phenology and soil fertility effects on below-ground carbon allocation for an annual (*Bromus madritensis*) and a perennial (*Bromus erectus*) grass species. *Soil Biology and Biochemistry*, *33*, 1291–1303.
- Weiner, J. (2004). Allocation, plasticity and allometry in plants. *Perspectives in Plant Ecology, Evolution and Systematics*, *6*, 207–215.
- Werth, M., & Kuzyakov, Y. (2008). Root-derived carbon in soil respiration and microbial biomass determination by ¹⁴C and ¹³C. *Soil Biology and Biochemistry*, *40*, 625–637.
- Whipps, J. M. (1990). Carbon economy. In J. M. Lynch (Ed.), *The rhizosphere* (pp. 59–97). Chichester: Wiley.
- Wu, Y., Tan, H., Deng, Y., Wu, J., Xu, X., Wnag, Y., ... Cui, X. (2010). Partitioning pattern of carbon flux in a Kobresia grassland on the Qinghai-Tibetan Plateau revealed by field ¹³C pulse-labeling. *Global Change Biology*, *16*, 2322–2333.
- Zak, D. R., Pregitzer, K. S., King, J. S., & Holmes, W. E. (2000). Elevated atmospheric CO₂, fine roots and the response of soil microorganisms: A review and hypothesis. *New Phytologist*, *147*, 201–222.
- Zhao, L., Chen, D., Zhao, N., Li, Q., Cheng, Q., Lua, C., ... Zhao, X. (2015). Responses of carbon transfer, partitioning, and residence time to land use in the plant-soil system of an alpine meadow on the Qinghai-Tibetan Plateau. *Biology and Fertility of Soils*, *51*, 781–790.

SUPPORTING INFORMATION

Additional Supporting Information may be found online in the supporting information tab for this article.

How to cite this article: Pausch J, Kuzyakov Y. Carbon input by roots into the soil: Quantification of rhizodeposition from root to ecosystem scale. *Glob Change Biol.* 2018;24:1–12. <https://doi.org/10.1111/gcb.13850>